



## PAIL # 61997

LID # 63475 (Snap On) / LID # 63306 (with or without Gasket) T.S.

### TECHNICAL DATA

**Capacity under lid:**  
63475: 15.95 L / 4.21 US gal.  
63306: 15.53 L / 4.10 US gal.

**Wall thickness:**  
Pail: (0.070 in.)  
Lid 63475: (0.051 in.)  
Lid 63306: (0.065 in.)

**Material:** Pail & lid: HDPE  
**Thermal range:** -38°C (-36°F) to 82°C (180°F)  
**Standard color:** white  
Other colors upon request

**Weight (approx.) without handle or gasket:**  
Pail: (590 g) 20.8 oz  
Lid 63475: (125 g) 4.4 oz  
Lid 63305: (168 g) 5.9 oz

**Handle:** plastic / metal

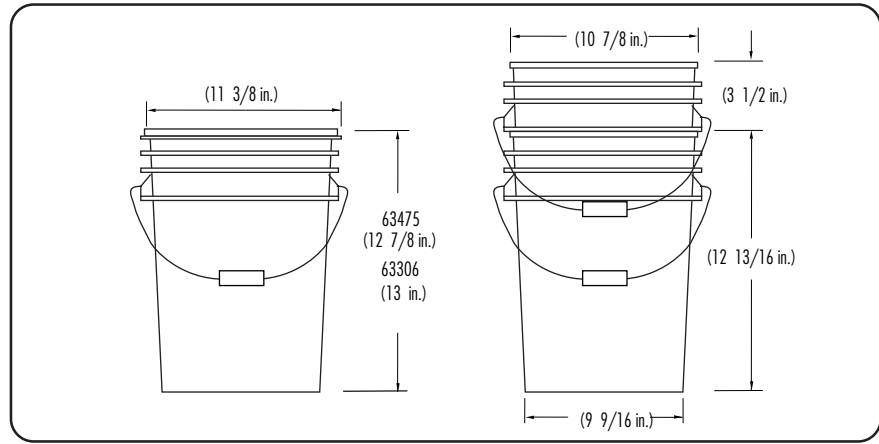

(Materials are recyclable or can be recovered for energy)

### TOP LOADING RESISTANCE

**90 kg (198 lb)** at 23°C / 73°F, 30 days. Product temperature when filling pails and warehouse temperature will affect pail performance. IPL recommends to make necessary testing prior to full production.

### PRINTING UP TO 4 COLORS DRY OFFSET

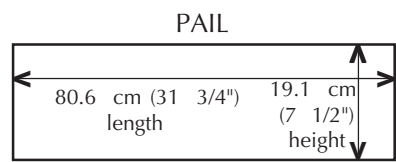

### PALLETIZATION OF FILLED PAIS

To determine the number of pails you can stack according to the product packed, divide the top loading resistance by the total weight of one filled pail. Take that number not rounded up and add the first unit

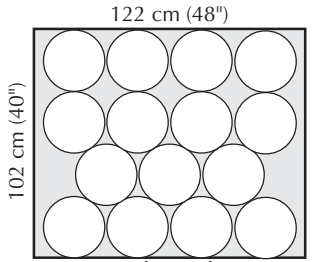

15 pails per layer  
**Stacked pails recommendation:**  
3 pails high / pallet

### OPENING AND CLOSING

**TO OPEN:** For tear strip lid, pull the tear strip then lift cover. Pry off with hands or use a lid opener for other lid.

**TO CLOSE:** Align lid on pail and press all around with hands or use a rubber mallet. Lid presses can be used (roller type or moving plate type).

### PACKAGING OF EMPTY PAIS/LIDS

**WAREHOUSING OF EMPTY PAIS:** 2 pallets high in warehousing

Approved by: *Stéphane Mercier*

**Approvals:** ..... Virgin materials are approved for food contact and meet FDA (Food and Drug Administration USA) and HPB (Health Protection Branch Canada) regulations.

**Advice:** ..... Handling conditions vary a lot from customer to customer, tests are recommended throughout the process of denesting, filling, conveying, palletization, warehousing, transportation and utilization by end users, etc. Specifications can be modified without notice. Please contact your IPL representative to confirm these data.

**Quality Assurance:**.. IPL is ISO 9001 certified and quality procedures are documented in our quality system.



**USA**  
IPL PRODUCTS, LTD.  
640 Lincoln Street  
Worcester, MA 01605  
Tel.: (508) 351-6050 Fax.: (508) 351-6044  
Toll free: 1-800-818-1318

**Canada**  
IPL INC.  
140 Commerciale  
St-Damien, QC  
Canada G0R 2Y0  
Tel : (418) 789-2880  
Fax : (418) 789-3153  
Toll free: 1-800-463-0270 Ext. 299

**Web Site**  
[www.ipl-packaging.com](http://www.ipl-packaging.com)