



**Tamper Evident  
CONTAINER # 60382 / LID # 60370**

**TECHNICAL DATA**

**Capacity under lid:**

4.86 L / 1.28 US gal.

**Wall thickness:**

Container: 0.09 cm (0.035 in.)

Lid: 0.13 cm (0.050 in.)

**Weight (approx.)**

Container: 119 g (4.2 oz.)

Lid: 72 g (2.5 oz.)

**Materials:** Cont. & lid: PP



**Thermal range:** 0 C (32 F) to 90 C (194 F)

**Standard color:** Natural

Other colors upon request

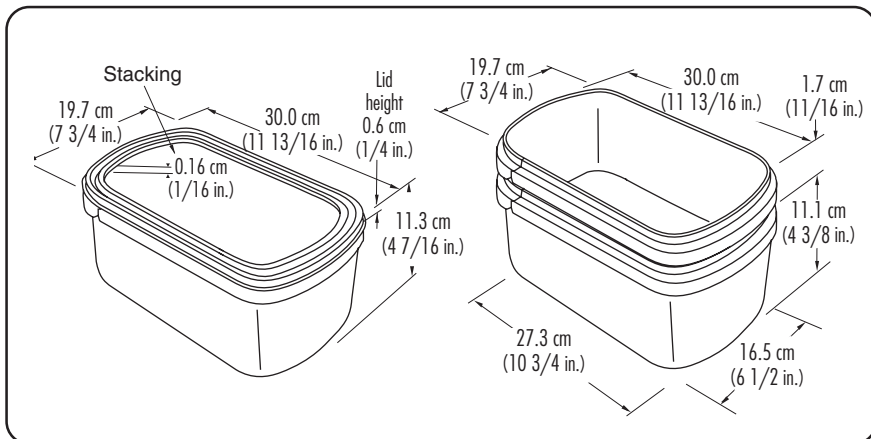

(Materials are recyclable or can be recovered for energy)

**TOP LOADING RESISTANCE**

**19 kg (41.9 lb.)** at 23 C [73 F].

Product temperature when filling containers and warehouse temperature will affect container performance.

IPL recommends to make necessary testing prior to full production.

**PALLETIZATION OF FILLED CONTAINERS**

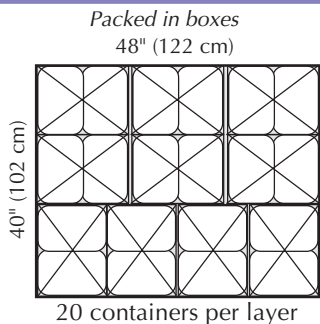

**Stacked container recommendation:  
4 Boxes high / pallet**

**PRINTING UP TO 4 COLORS, DRY OFFSET**

LID ONLY

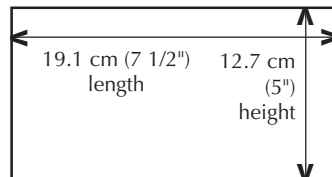

**OPENING AND CLOSING**

TO OPEN: Break the Tamper-Evident tab, then remove lid.

TO CLOSE: Align lid on container, then press all the way around.

**PACKAGING OF EMPTY CONTAINERS/LIDS**

WAREHOUSING OF EMPTY CONTAINERS: 1 pallet-3 bundles  
No double stacking. Racking recommended.

Approved by:

**Approvals:** ..... Virgin materials are approved for food contact and meet FDA (Food and Drug Administration USA) and HPB (Health Protection Branch Canada) regulations.

**Advise:** ..... Handling conditions vary a lot from customer to customer, tests are recommended throughout the process of denesting, filling, conveying, palletization, warehousing, transportation and utilization by end users, etc. Specifications can be modified without notice. Please contact your IPL representative to confirm these data.

**Quality Assurance:** . IPL is ISO 9001 certified and quality procedures are documented in our quality system

