



## CONTAINER # 60373 / LID # 63329

### TECHNICAL DATA

**Capacity under lid:**

6.00 L / 1.58 US gal.

**Wall thickness:**

Container: (0.042 in.)

Lid: (0.038 in.)

**Weight (approx.)**

Container: 195 g (6.88 oz.)

Lid: 120 g (4.3 oz.)

**Materials:** Cont. & lid: PP



**Thermal range:** 0 C (32 F) to 90 C (194 F)

**Standard color :** Natural

Other colors upon request

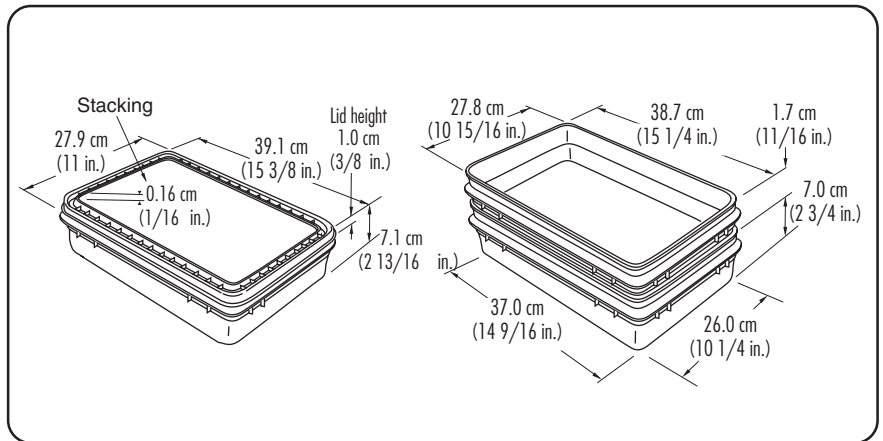

(Materials are recyclable or can be recovered for energy)

### TOP LOADING RESISTANCE

**30 kg (66 lb.)** at 23 C [73 F].

Product temperature when filling containers and warehouse temperature will affect container performance.

IPL recommends to make necessary testing prior to full production.

### PRINTING UP TO 4 COLORS, DRY OFFSET

LID ONLY

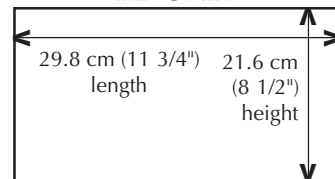

### PALLETIZATION OF FILLED CONTAINERS

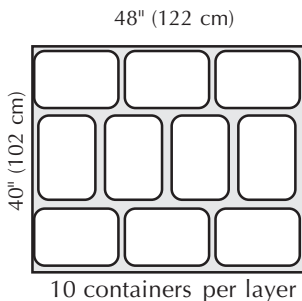

### OPENING AND CLOSING

TO OPEN: Gradually lift the lip of the lid all around the container.

TO CLOSE: Align lid on container, then press all the way around.

### PACKAGING OF EMPTY CONTAINERS/LIDS

WAREHOUSING OF EMPTY CONTAINERS: 1 pallet- 2 bundles  
No double stacking. Racking recommended.

Approved by: *[Signature]*

**Approvals:** ..... Virgin materials are approved for food contact and meet FDA (Food and Drug Administration USA) and HPB (Health Protection Branch Canada) regulations.

**Advise:** ..... Handling conditions vary a lot from customer to customer, tests are recommended throughout the process of denesting, filling, conveying, palletization, warehousing, transportation and utilization by end users, etc. Specifications can be modified without notice. Please contact your IPL representative to confirm these data.

**Quality Assurance:** . IPL is ISO 9001 certified and quality procedures are documented in our quality system



**USA**  
IPL PRODUCTS, LTD.  
640 Lincoln Street  
Worcester, MA 01605  
Tel.: (508) 351-6050 Fax.: (508) 351-6044  
Toll free: 1-800-818-1318

**Canada**  
IPL INC.  
140 Commercial  
St-Damien, QC  
Canada G0R 2Y0  
Tel : (418) 789-2880  
Fax : (418) 789-3153  
Toll free: 1-800-463-0270 Ext. 299

**Web Site**  
[www.ipl-packaging.com](http://www.ipl-packaging.com)