

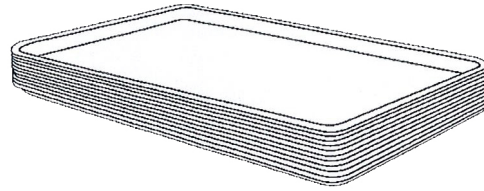

FoodPro Tray



No. 61682

COMPONENTS

Material: Polypropylene
Standard colors: white
or green
Other colors on request

WALL THICKNESS

0.34 cm (0.135 in.)

STANDARD WEIGHT

(± 2%)
1.23 kg (2.7 lb)

RATIO

Nesting 4 : 1

DIMENSIONS

PACKING

SHIPPING

Pallet dimensions:
135 cm x 102 cm x 120 cm H
53 in. x 40 in. x 47 in. H
Volume/pallet: 1.7 m³ (61.3 feet³)
Weight/pallet: (pallet not included)
593 kg (1,307 lb)
Quantity/pallet: 480
Quantity/truckload: 11,040

TOP LOADING RESISTANCE

25 kg (55 lb) @ 23° C/30 days

THERMAL RESISTANCE

From -35°C (-31°F) to
50°C (122°F)

RECOMMENDED HANDLED WEIGHT

16 kg (35 lb)

APPROVALS

Materials are food approved
and meet FDA (Food & Drug
Administration-USA)

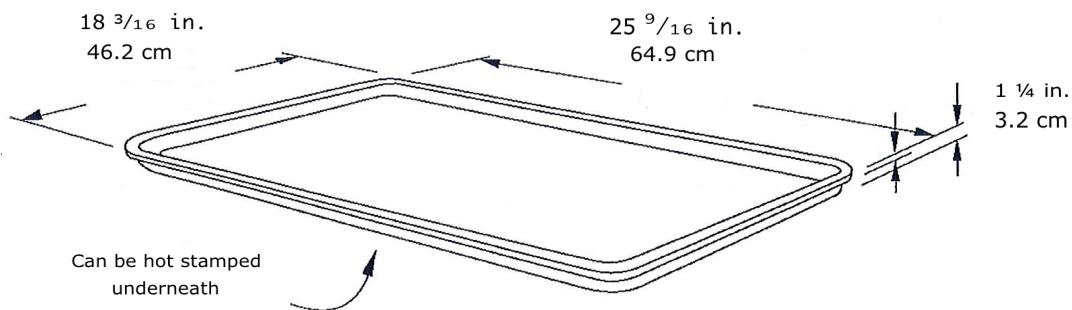

NESTABLE

Inside dimensions:

Length: 61.2 cm (24 1/8 in.)
Width: 42.0 cm (16 1/2 in.)
Height: 2.86 cm (1 1/8 in.)

The drawing is for illustrative purpose only

