

SEALPACK SQUARE



A MODERN SQUARE FILM SEAL CONTAINER

Modern design with a reduce foot print. Ideal for deli products requiring high pressure pasteurization.

KEY FEATURES AND BENEFITS

- Film-Sealable
- Less resin than our existing square or round series
- Withstands high pressure pasteurization*
- Photo-quality IML decoration
- Space saving vs. same size round containers
- Microwave and dishwasher safe

TECHNICAL SPECIFICATIONS

CONTAINERS

PRODUCT CODE	MODEL	DECORATION OPTIONS**		BRIMFUL CAPACITY		APPROX. WEIGHT		A OVERALL HEIGHT		B OVERALL WIDTH		ITEMS PER BOX	BOXES PER PALLET	ITEMS PER PALLET
		IML	Offset	US fl.oz.	ml	oz.	g	in.	mm	in.	mm			
22530	8 oz. / 250 ml	✓	3/5	11.46	339	0.34	9.6	1.79	45.5	4.17	105.9	1,120	16	17,920
23530	12 oz. / 350 ml	✓	3/5	15.22	450	0.45	12.8	2.37	60.2	4.17	105.9	1,120	16	17,920
25030	16 oz. / 500 ml	✓	3/5	18.80	556	0.54	15.4	2.93	74.5	4.17	105.9	920	16	14,720
21150	32 oz. / 1 L	✓	3	35.88	1,061	0.86	24.5	2.94	74.7	5.73	145.5	384	20	7,680
21550	48 oz. / 1,5 L	✓	3	52.75	1,560	1.27	36.1	4.33	110.0	5.73	145.5	288	20	5,760

* See our HPP Guide to know more about HPP use and limitations on this series

** Development is possible for 5 face label on all sizes

LIDS

PRODUCT CODE	MODEL - ASSOCIATED CONTAINERS	DECORATION OPTIONS		APPROX. WEIGHT		A HEIGHT		B WIDTH		ITEMS PER BOX	BOXES PER PALLET	ITEMS PER PALLET
		IML	Offset	oz.	g	in.	mm	in.	mm			
20130	8 oz. (250 ml), 12 oz. (350 ml), 16oz (500 ml)	✓		0.21	5.9	0.55	14.0	4.21	106.9	1,512	30	45,360
20150	32 oz. (1 L), 48 oz. (1,5 L)	✓		0.59	16.8	0.75	19.1	5.80	147.4	720	25	18,000

COLOR OPTIONS

BASE COLORS	STANDARD COLORS	OTHER COLORS
Natural 000	Yellow 012	Available upon request
White 001	Orange 021	
Clear 002	Red 485	
	Green 377	
	Blue 293	
	Black 099	

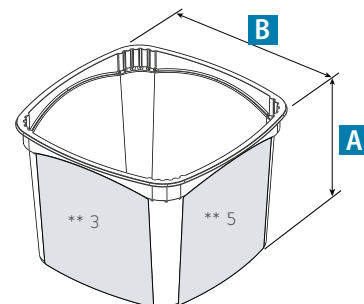

** 3: FRONT + BOTTOM + BACK
5: 3 + SIDES

1-800-647-0602
ipl-plastics.com



CERTIFICATIONS

The raw materials used are tested according to ASTM standards for polymers, are approved for food contact and meet FDA (Food and Drug Administration, USA) and HPB (Health Protection Branch, Canada) regulations.



MATERIAL

Containers, lids and IML labels are made of 100% recyclable polypropylene (PP).



MINIMUM ORDERS INFORMATION

For details on minimum order quantities or for any other additional information, please contact IPL customer care at 1-800-647-0602 or visit our web site at www.ipl-plastics.com.

RECOMMENDATIONS

Handling conditions vary from customer to customer. We recommend validating your processes (filling, conveying, warehousing and any others that might affect the purchased part) prior to use. Product usage temperature is between -9.4°F (-23°C) and 179.6°F (82°C) depending on resin grade.

WARRANTIES

Some chemicals can affect the integrity of the product. Any product requiring a Safety Data Sheet (SDS) has to be submitted and approved by IPL. If buyer fails to adhere to this clause, the related product guarantees will be void.

Specifications may vary slightly over time. Please contact your IPL representative to ensure you have the most recent information.

The information presented herein was prepared at IPL Inc. by qualified technical personnel. To IPL's knowledge, it is true and accurate. However, the information and recommendations are furnished for these products with the understanding that the purchaser or user will independently determine that the product is suitable for the intended use, and that such use, complies with all applicable laws and regulations. The data represents typical values submitted only for the user's information and consideration and does not constitute a warranty of any kind.

ABOUT

IPL inc. Consumer Packaging Solutions is a division of IPLP Group. To learn more, visit www.iplpgroup.com.

PROJECT?

Not sure you found what you need?

Need a custom design?

Get in touch with one of our retail and consumer packaging expert!

info@ipl-plastics.com

www.ipl-plastics.com